

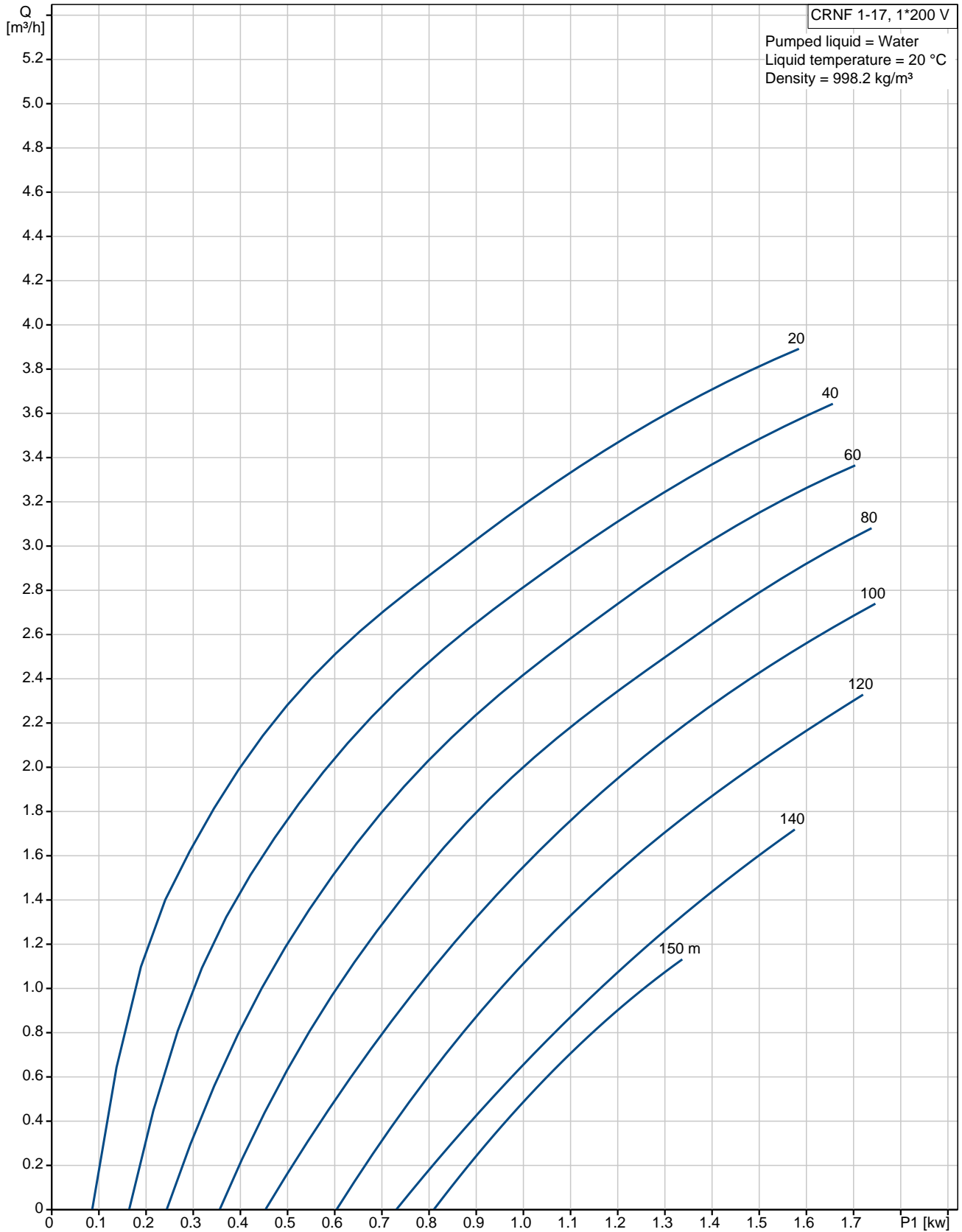

98415305 CRNF 1-17 50 Hz



Description	Value
-------------	-------

General information:

Product name:	CRNF 1-17 A-CA-G-E-HQQE
Position:	
Product No:	98415305
EAN number:	5711494633548
Price:	On request

Technical:

Speed for pump data:	3501 rpm
Rated flow:	2.2 m³/h
Rated head:	116 m
Impellers:	17
Shaft seal:	HQQE
Approvals on nameplate:	CE, TR
Stages:	17
Pump version:	A
Model:	A

Materials:

Pump housing:	Stainless steel DIN W.-Nr. 1.4408 AISI 316 ASTM A 351 CF 8M
Impeller:	Stainless steel DIN W.-Nr. 1.4401 AISI 316
Material code:	G
Code for rubber:	E

Installation:

Maximum ambient temperature:	50 °C
Max pressure at stated temp:	25 bar / 120 °C
	25 bar / -20 °C
Flange standard:	CLAMP
Connect code:	CA
Pipe connection:	FLEXICLAMP
Flange size for motor:	FT115

Liquid:

Pumped liquid:	Water
Liquid temperature range:	-20 .. 120 °C
Liquid temp:	20 °C
Density:	998.2 kg/m³
Kinematic viscosity:	1 mm²/s

Electrical data:

Motor type:	90SC
Power input - P1:	1.73 kW
Rated power - P2:	1.5 kW
Rated voltage ac:	1 x 90-240 V
Rated voltage dc:	30 - 300 V
Cos phi - power factor:	0,99
Rated speed:	500-3600 rpm
Enclosure class (IEC 34-5)::	IP55
Insulation class (IEC 85):	F
Motor protec:	YES
Motor No:	98190192

Controls:

Control panel:	HMI200 - Standard
Function Module:	FM300 - Advanced

Others:

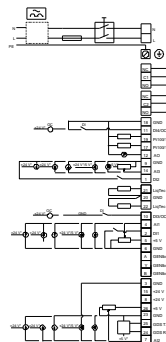
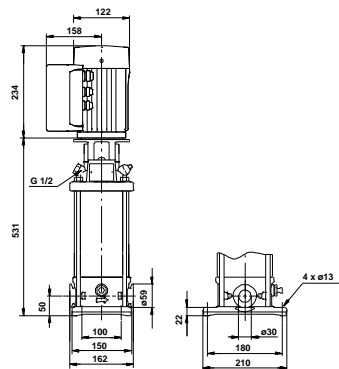
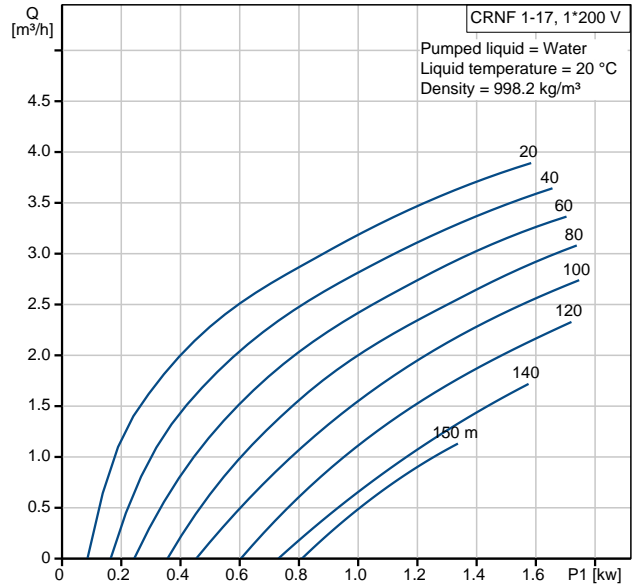



Company name: -
Created by: -
Phone: -
Fax: -
Date: -

Description	Value
Net weight:	33.5 kg
Gross weight:	39.2 kg
Config. file no:	98412558



98415305 CRNF 1-17 50 Hz

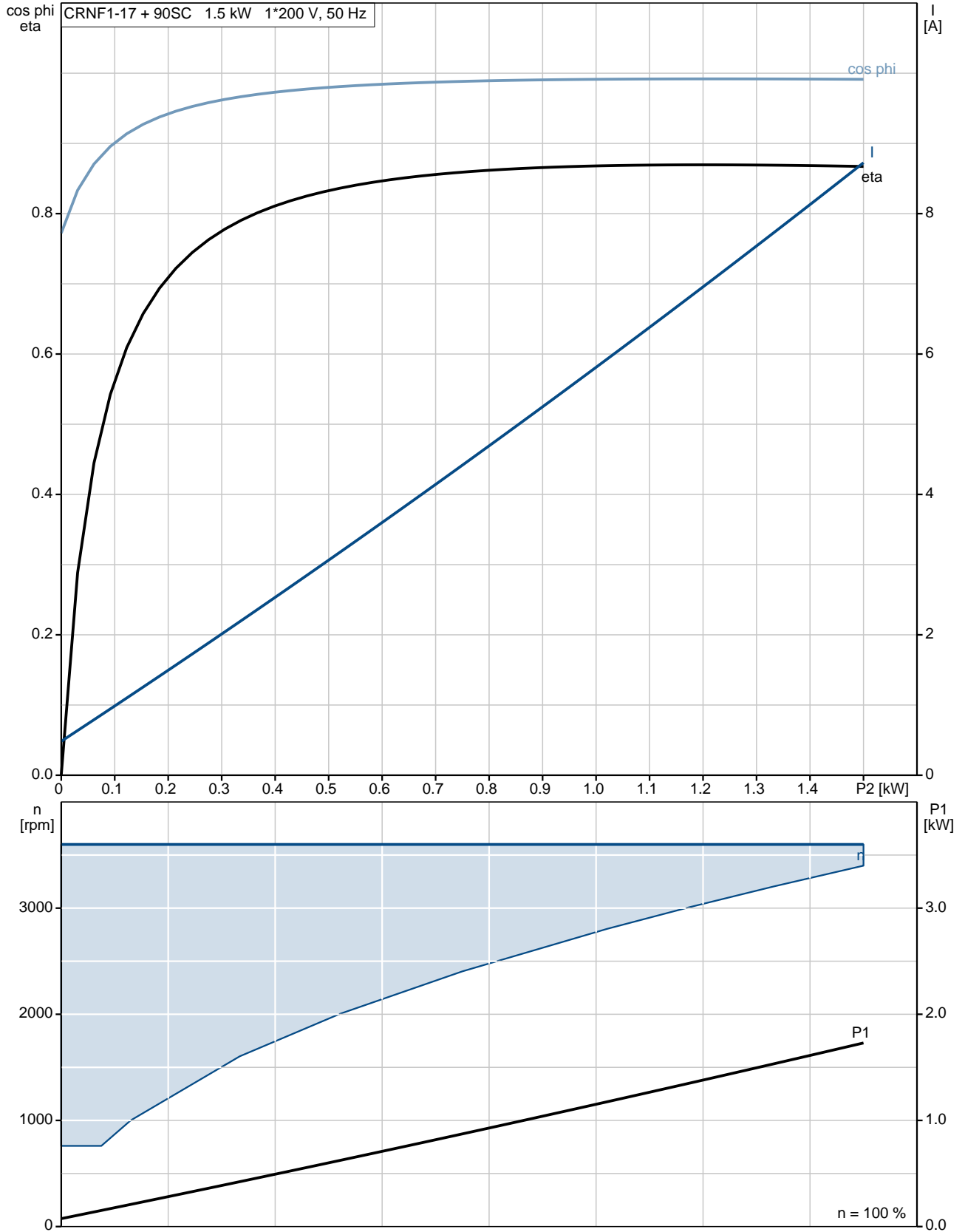



98415305 CRNF 1-17 50 Hz

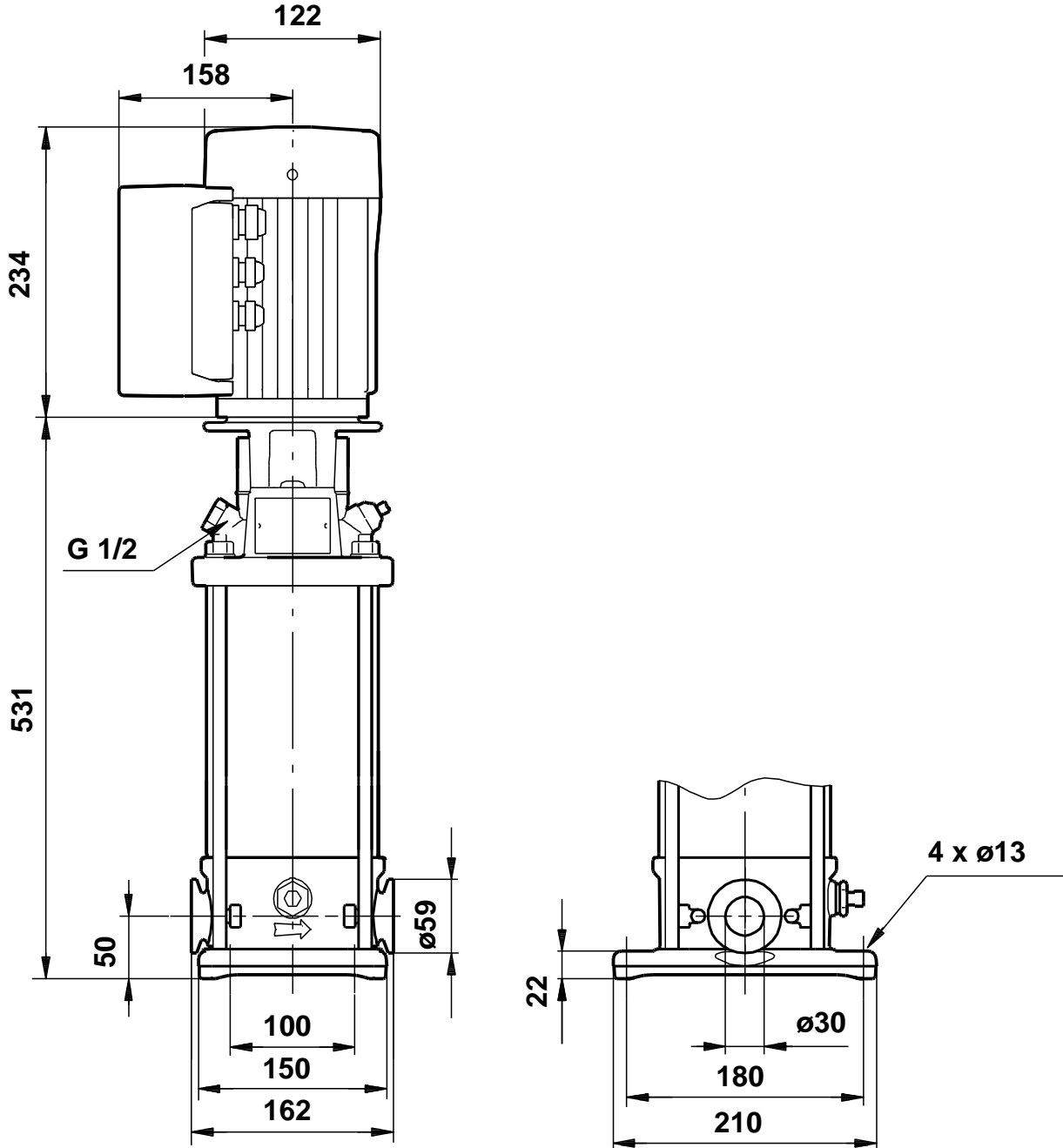

Note! All units are in [mm] unless others are stated.
Disclaimer: This simplified dimensional drawing does not show all details.

98415305 CRNF 1-17 50 Hz

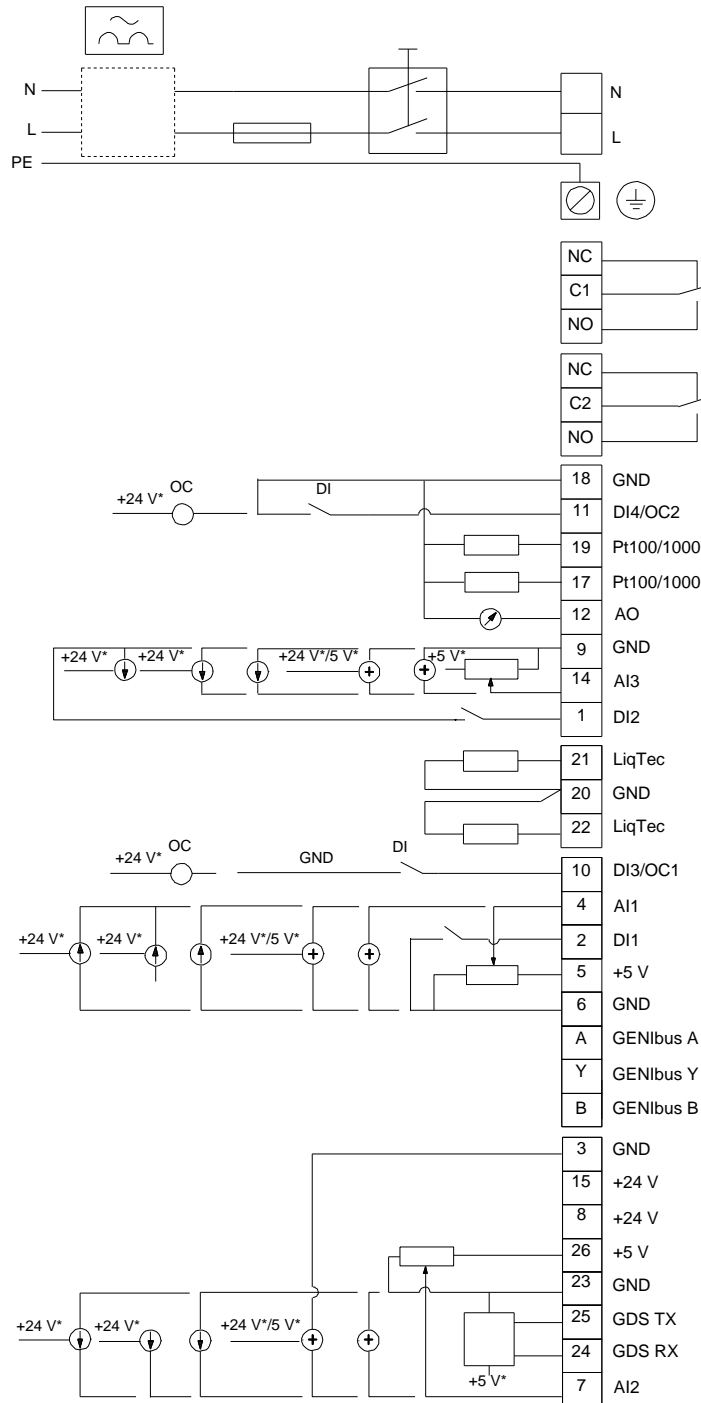

Note! All units are in [mm] unless others are stated.